



Shenzhen Flourish Electronics Co., LTD

FILE NO.

QC-T4-09

Ver:

1.0

(C) D- C

Page

1/13



SPECIFICATION FOR APPROVAL



Table of Contents



Shenzhen Flourish Electronics Co., LTD

(C) D- C

FILE NO. QC-T4-09

Ver: 1.0

Page 3/13



Shenzhen Flourish Electronics Co., LTD

FILE NO.

QC-T4-09

Ver:

1.0

(C) D- C

Page

4/13

Features



Test Condition



Shenzhen Flourish Electronics Co., LTD

(C) D- C

FILE NO.

QC-T4-09

Ver:

1.0

Page

5/13



Shenzhen Flourish Electronics Co., LTD

FILE NO.

QC-T4-09

Ver:

1.0

(C) D- C

Page

6/13

(Specification details & dimensions)

μ



Shenzhen Flourish Electronics Co., LTD

FILE NO.

QC-T4-09

Ver:

1.0

(C) D- C

Page

7/13

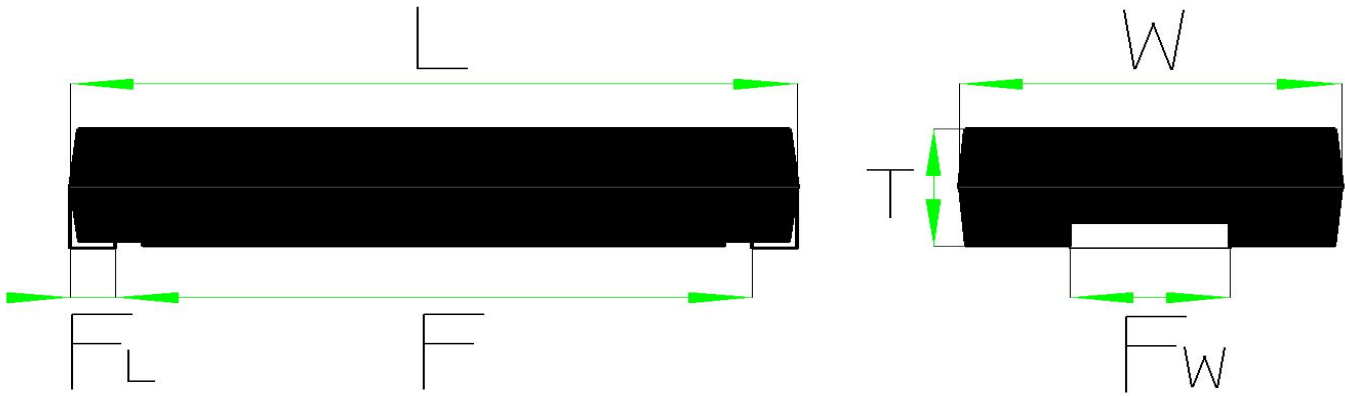

	±	±	±	±	±	±

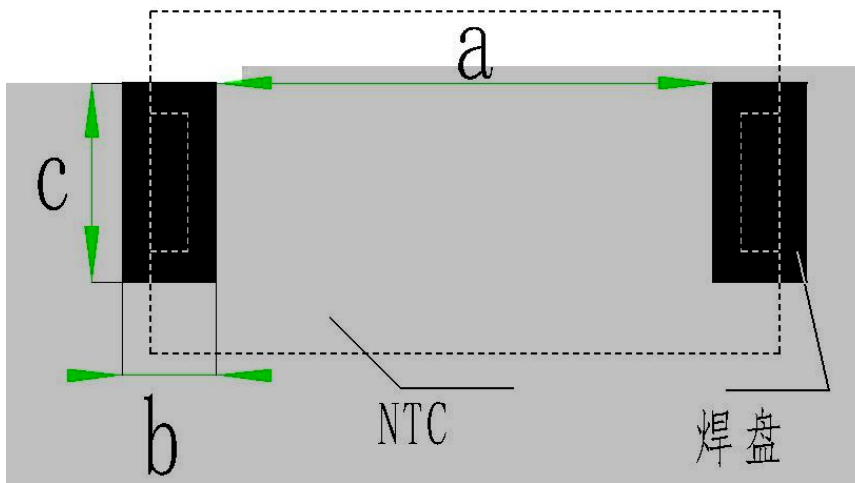

(Marking Explain)

Safety Certification:



Structure

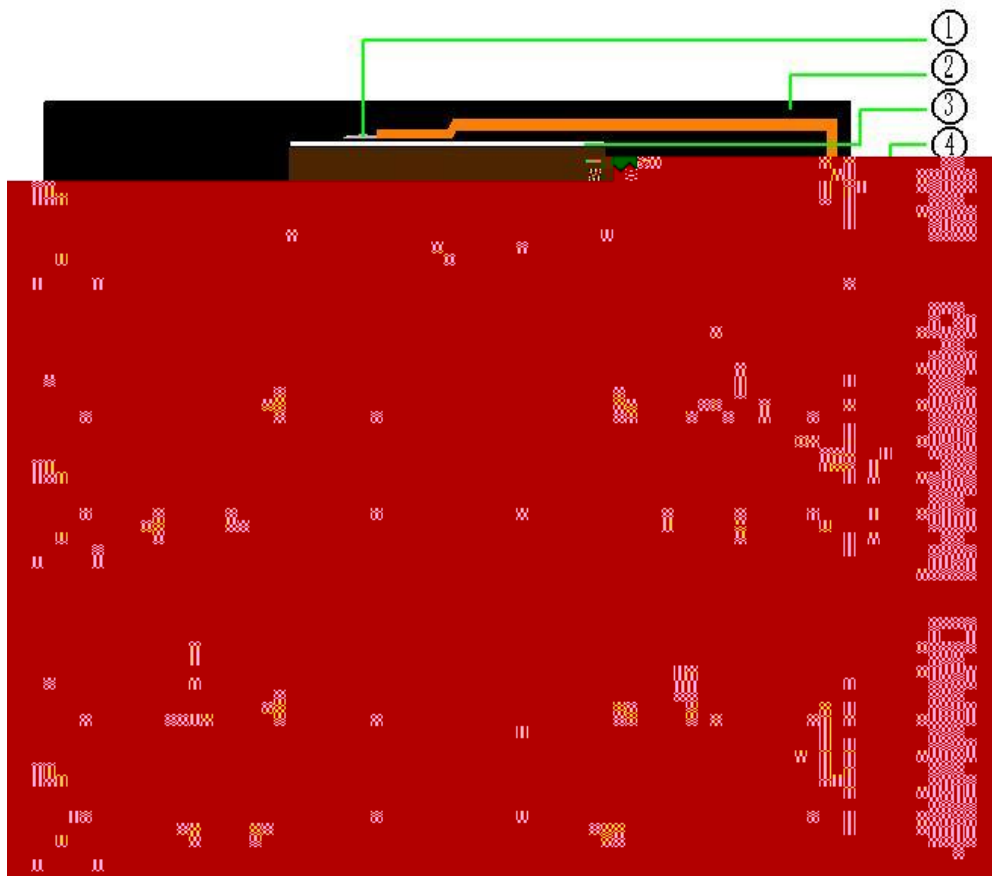

packing description

6.1

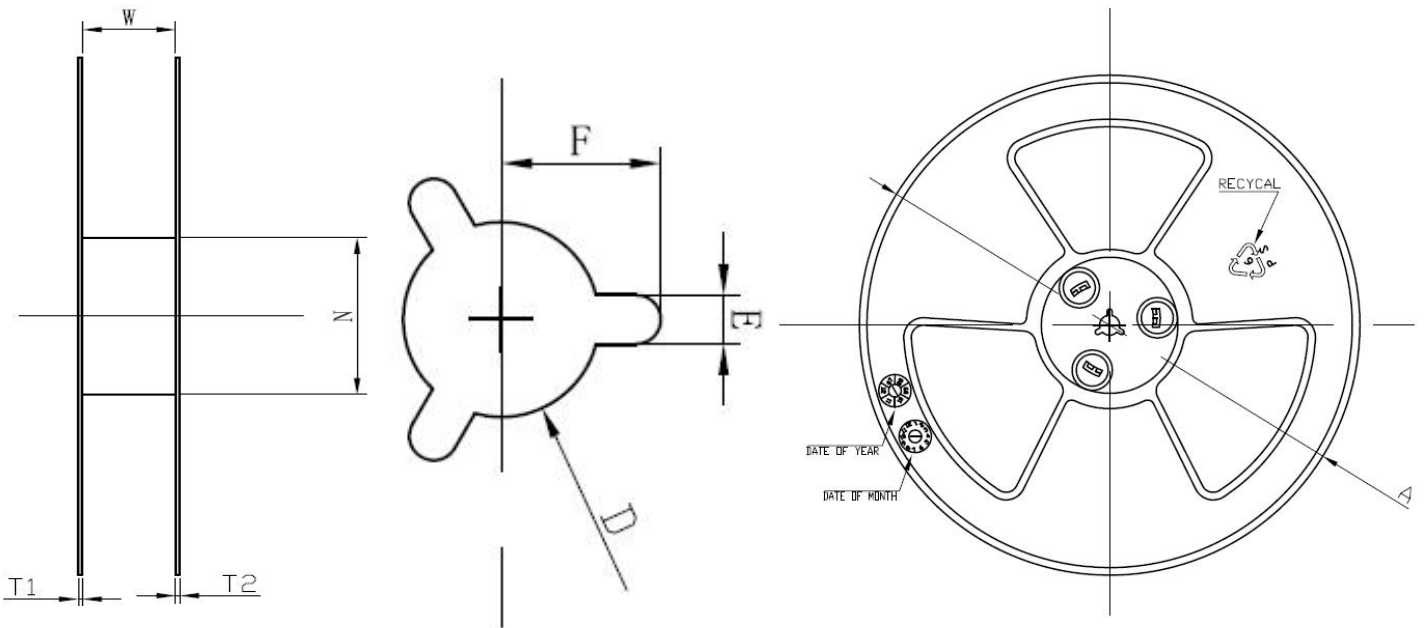
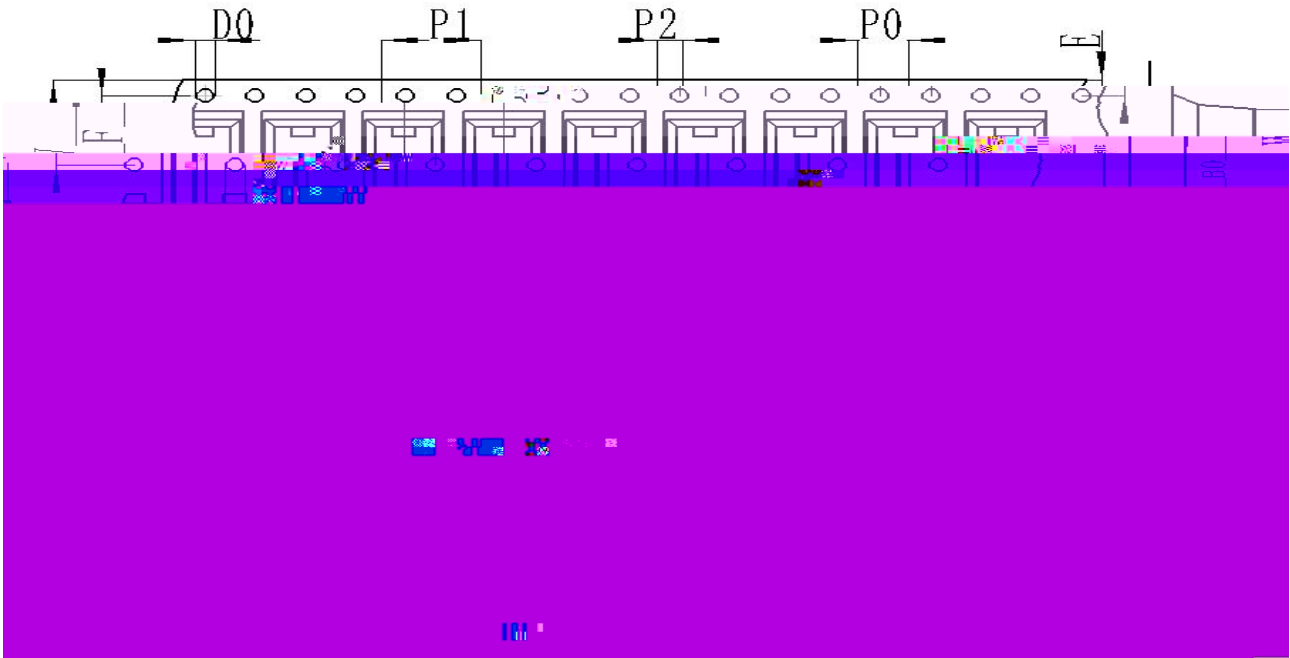

	±	±	±	±	±	±	±	±

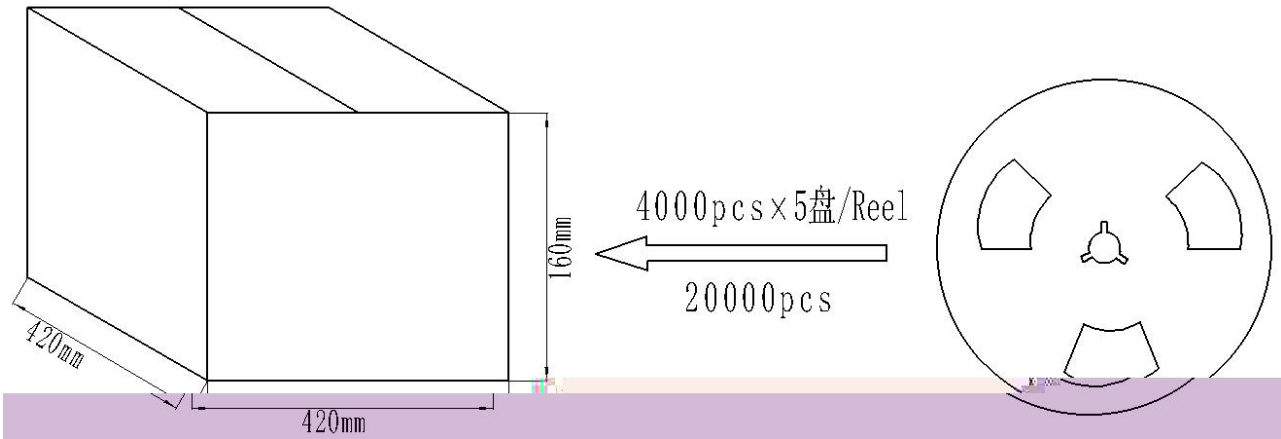

Welding according to the instruction

7.1

☆ 回流焊接曲线

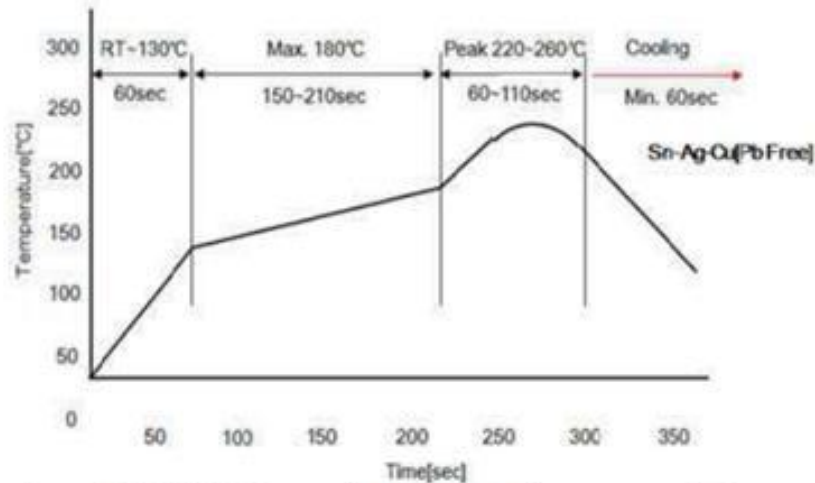

温区	温度范围 (°C)	时间 (sec)	备注
a	RT~130	60	焊锡: Sn-Ag-Cu 高温时间: < 10 sec
b	180 max	150~210	
c	220~260(260 max)	60~110	
d	220~RT	60 min	

当焊接温度低于锡的熔点时，贴片镀锡端子的可焊性将下降。使用之前请确认贴片镀锡电极的可焊性。焊接区出风口及内部空间最高温度不能超过 280°C，温度超过时，会造成产品发生失效。由于超温使用所造成的不良，我司不予承担责任。



7.2.

!

! ()

Level	Bake@40C 5%RH	
	Saturated@30C/85%RH	At limit of Floor Life+7 @30C/60RH
3	79days	67days

!

!



7.4

!

()